



*The University of Tennessee at Martin*

**School of Engineering**

# **Involute Gear Tooth Bending Stress Analysis**

## **Lecture 21**

### **Engineering 473**

### **Machine Design**



# Gear Interaction

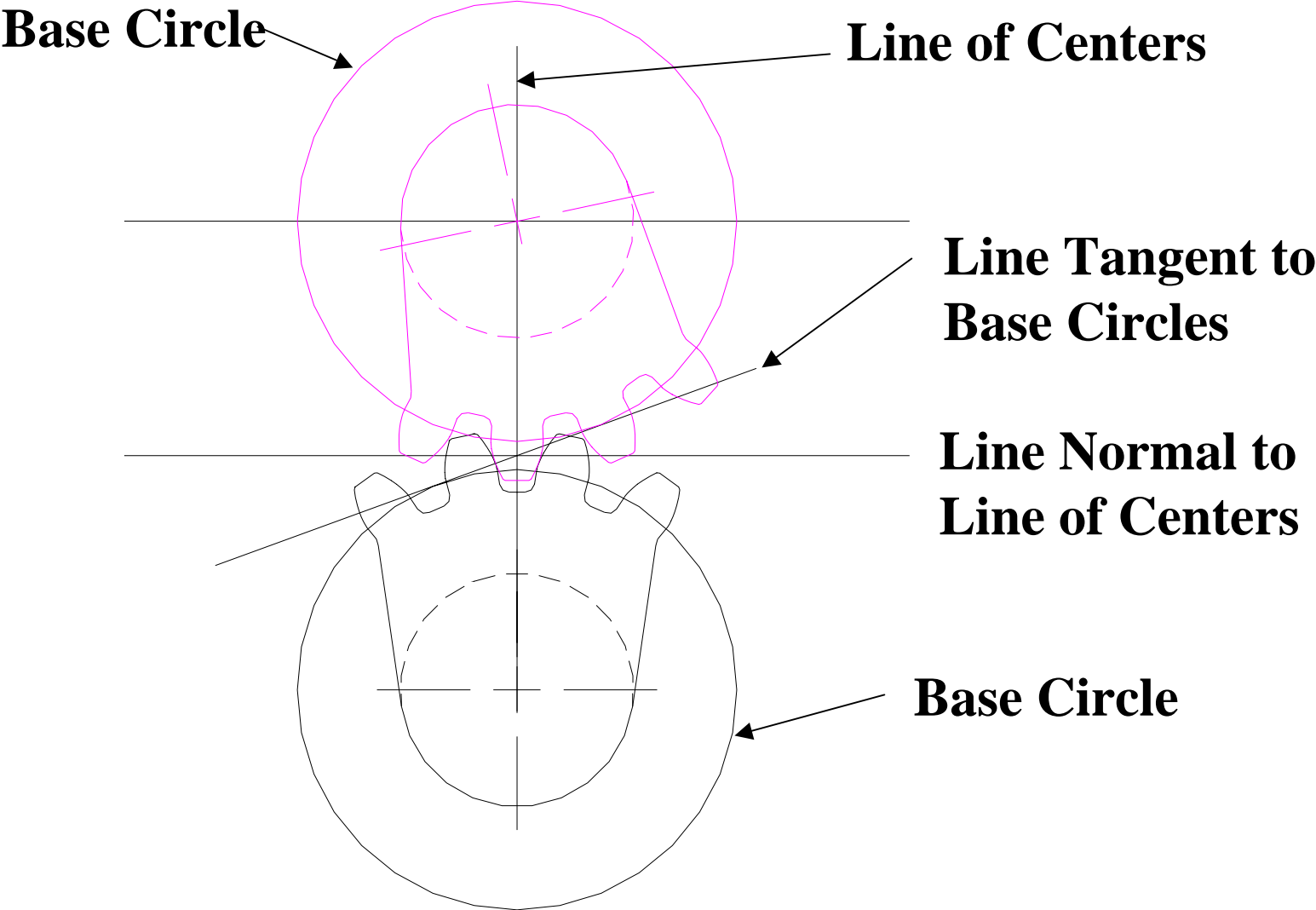

# 1<sup>st</sup> Close Up of Meshed Teeth

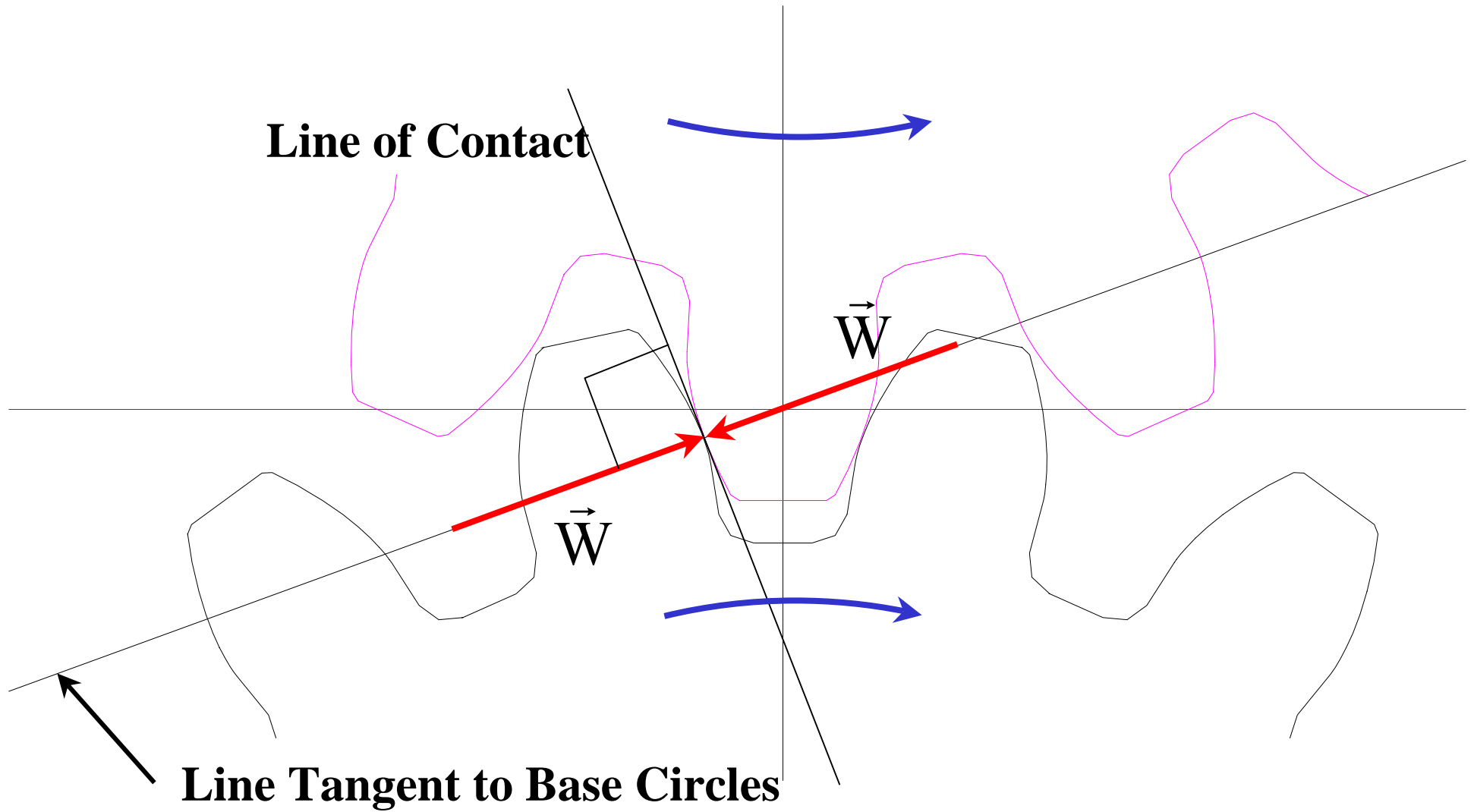

# 2<sup>nd</sup> Close Up of Meshed Teeth

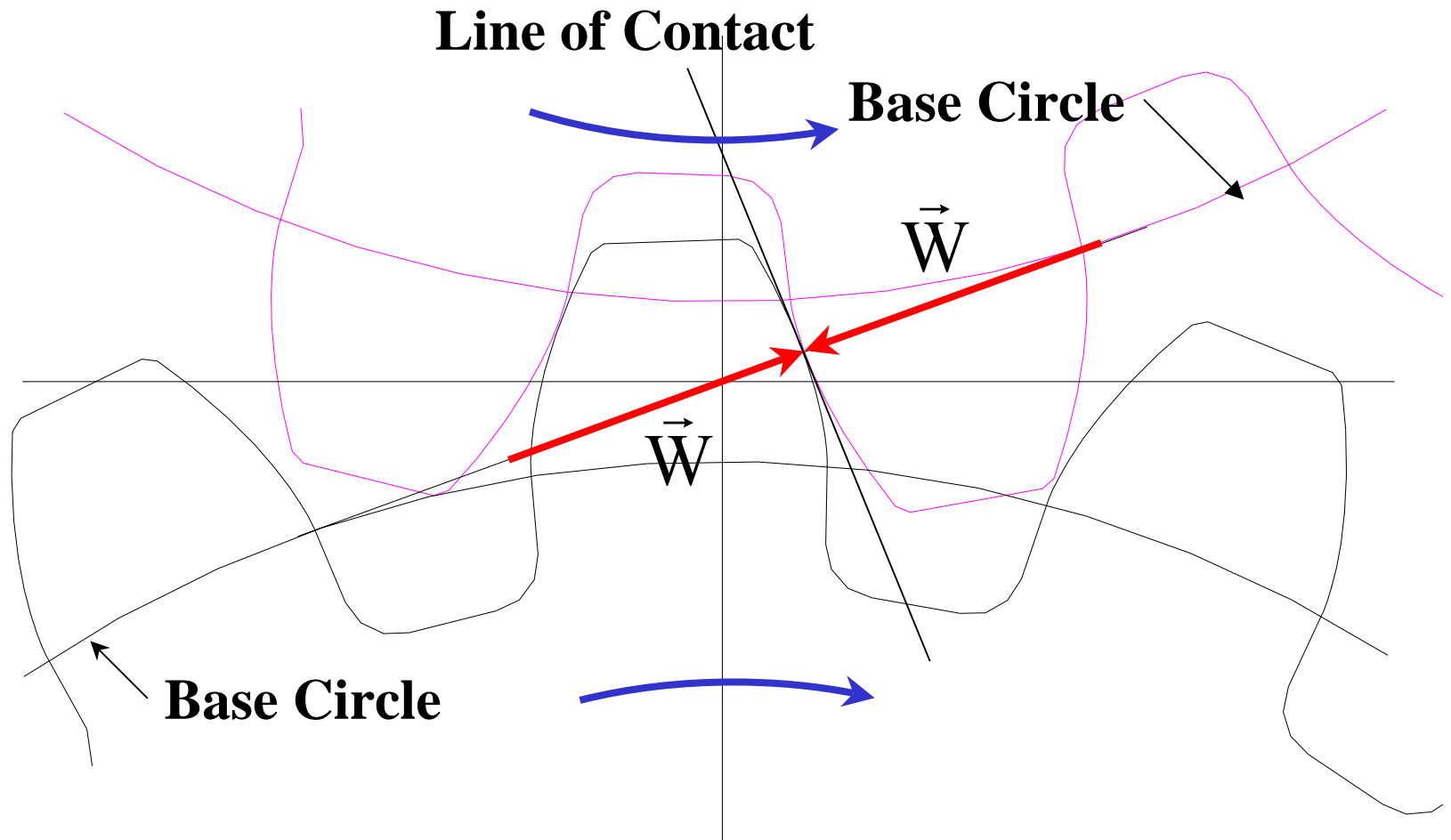

# 3<sup>rd</sup> Close Up of Meshed Teeth

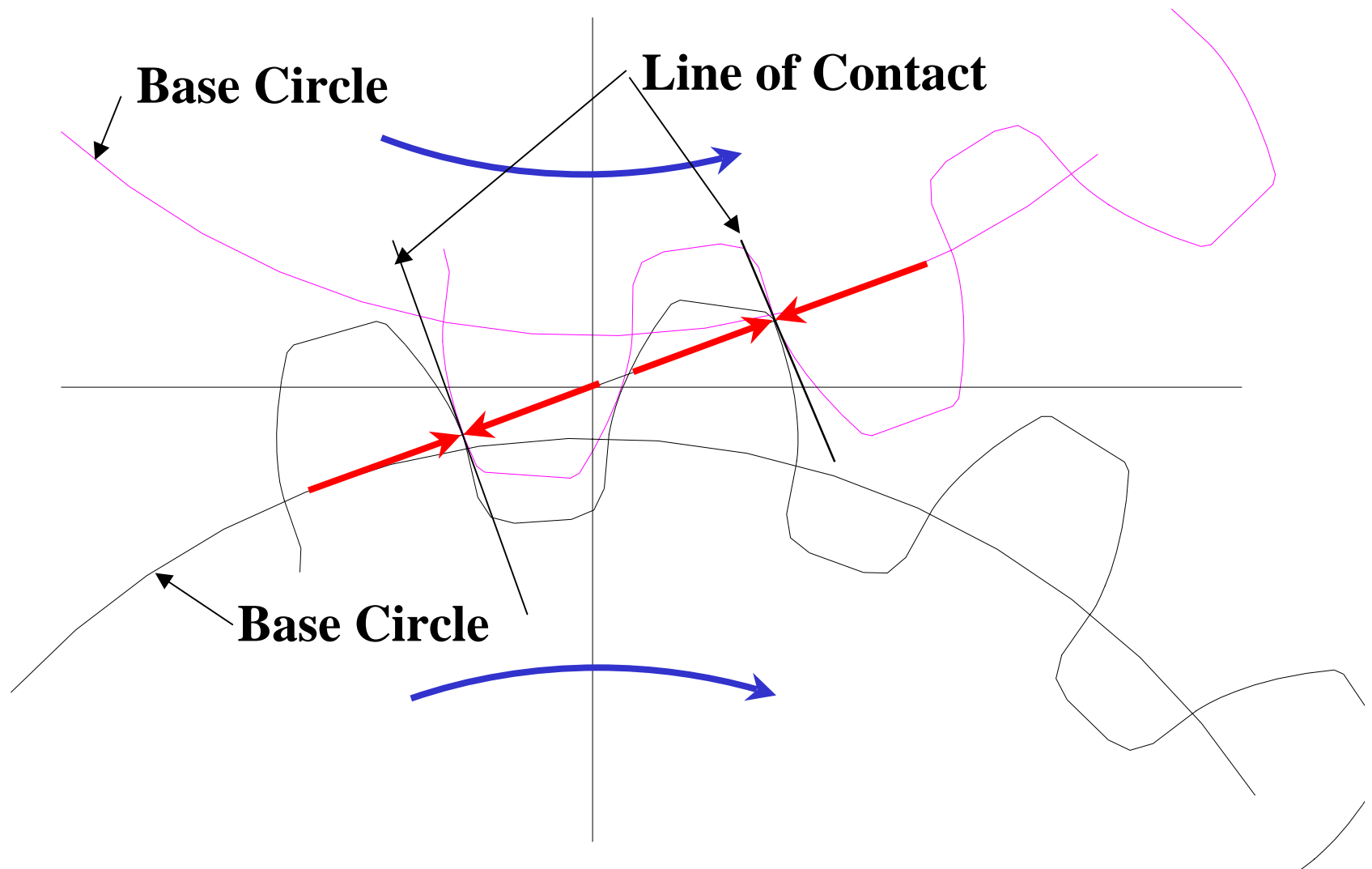

# Line of Action/Pressure Angle

**Line of Action** – Line tangent to both base circles

**Pressure Angle** – Angle between the line normal to the line of centers and the line of action.

**Pitch Point** – Intersection of the line of centers with the line of action

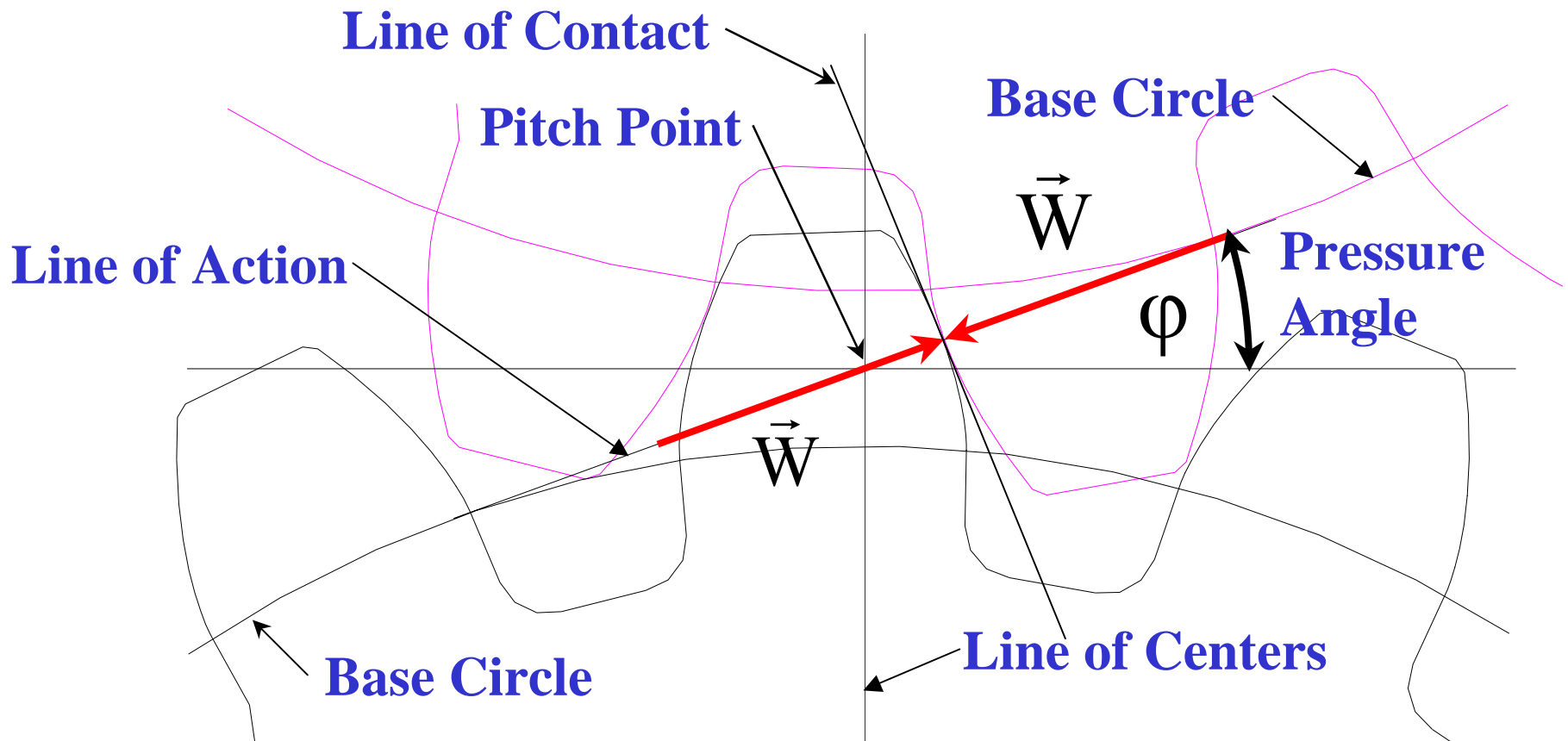

# Pitch Circle

**Pitch Circle** – Circle with origin at the gear center and passing through the pitch point.

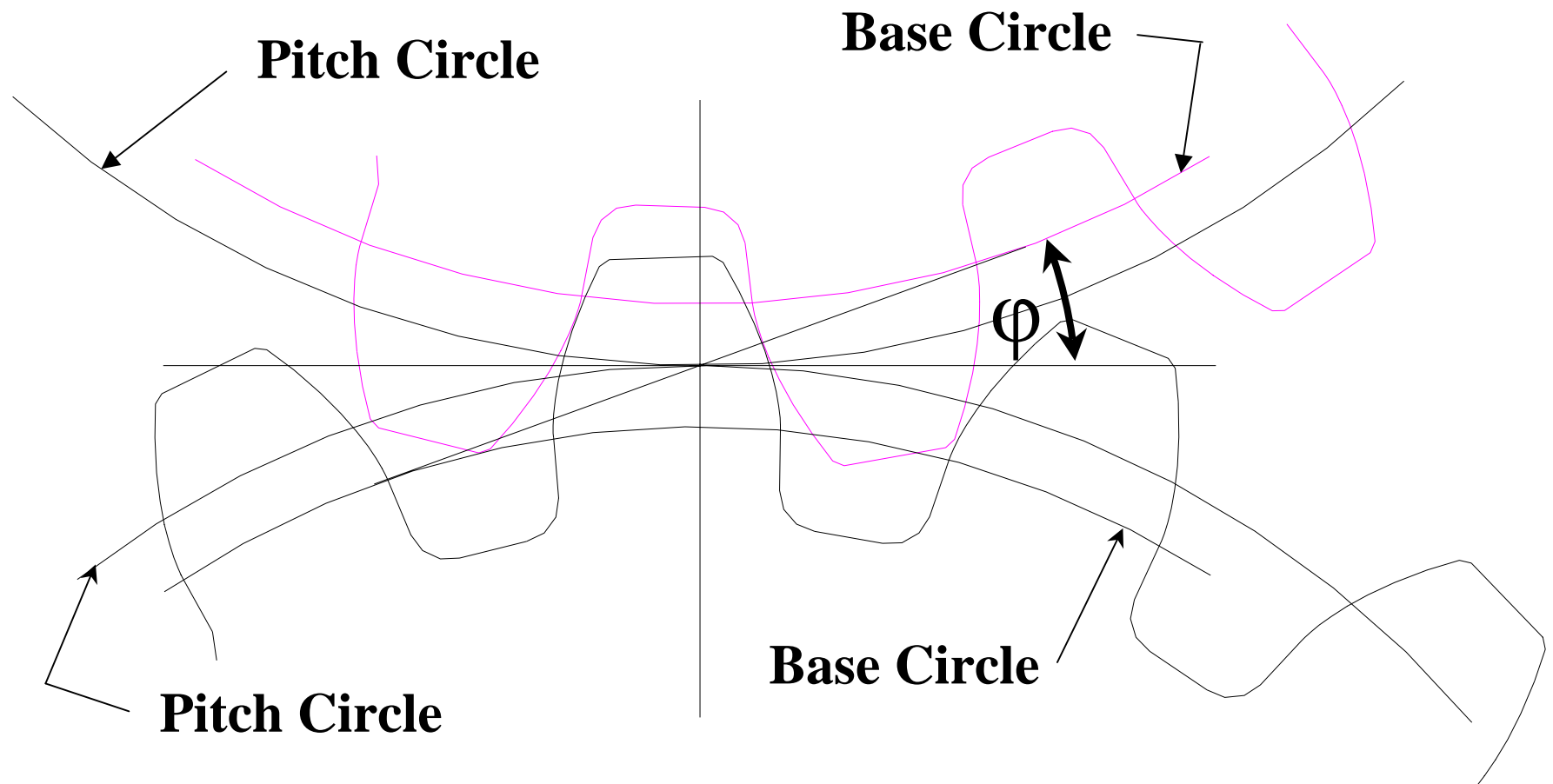

# Relationship Between Pitch and Base Circles

$$r_b = r \cos(\varphi)$$

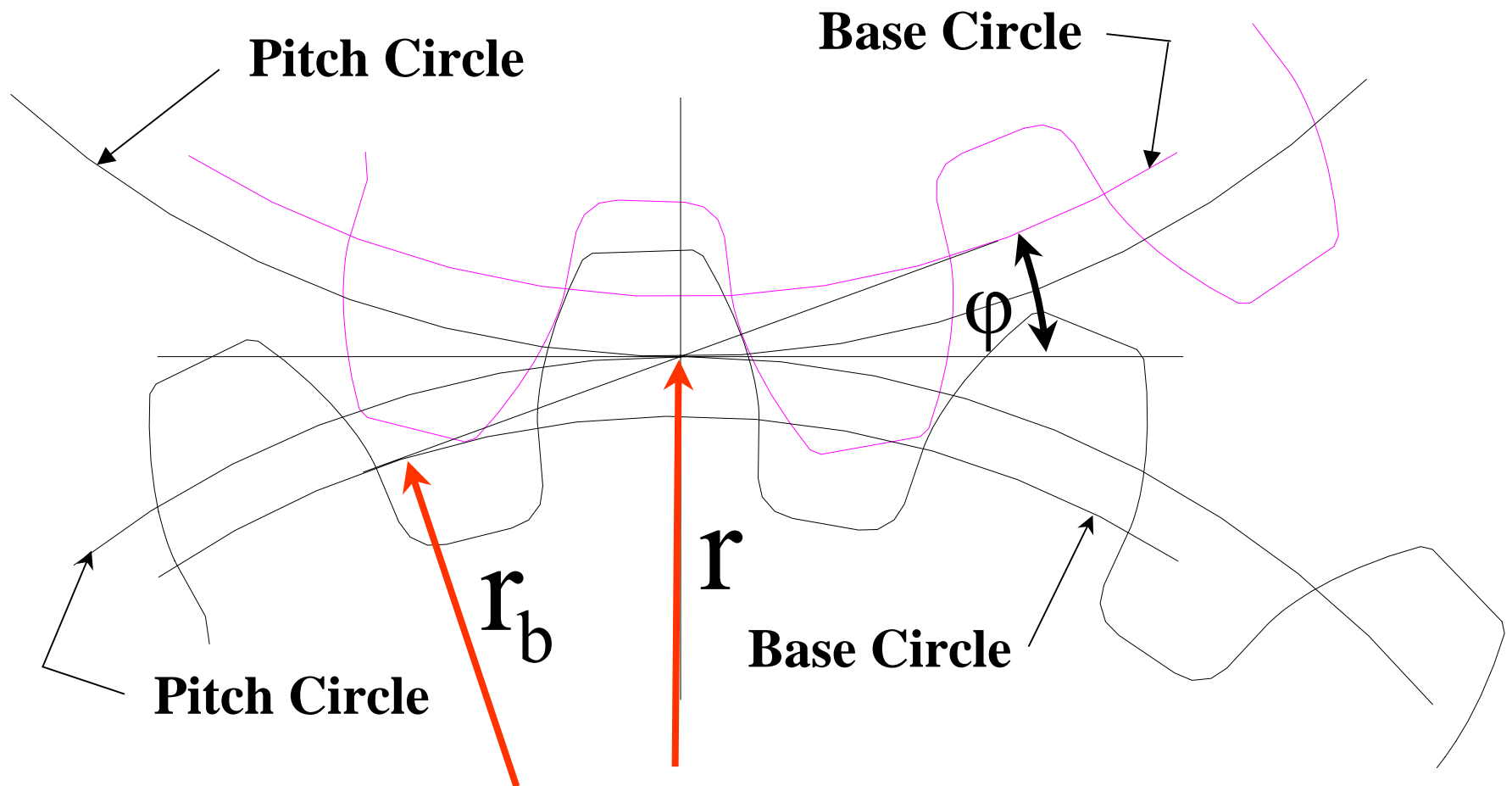

# Torque Relationship

$$T \equiv \frac{\text{Power}}{\text{Angular Velocity}} = \frac{P}{\omega}$$

$$T = \frac{P(\text{hp})}{n \text{ (rev/min)}} \cdot \frac{550 \text{ lb} \cdot \text{ft}/\text{sec}}{1.0 \text{ hp}} \cdot \frac{1.0 \text{ rev}}{2\pi \text{ rad}} \cdot \frac{60 \text{ sec}}{\text{min}} \cdot \frac{12 \text{ in}}{\text{ft}}$$

$$T = 63,000 \frac{P}{n} (\text{lb} \cdot \text{in})$$

# Tooth Load Equations

$$W_t = \frac{T}{d/2} \quad W_r = W_t \cdot \tan\phi \quad |\vec{W}| = W_t / \cos\phi$$

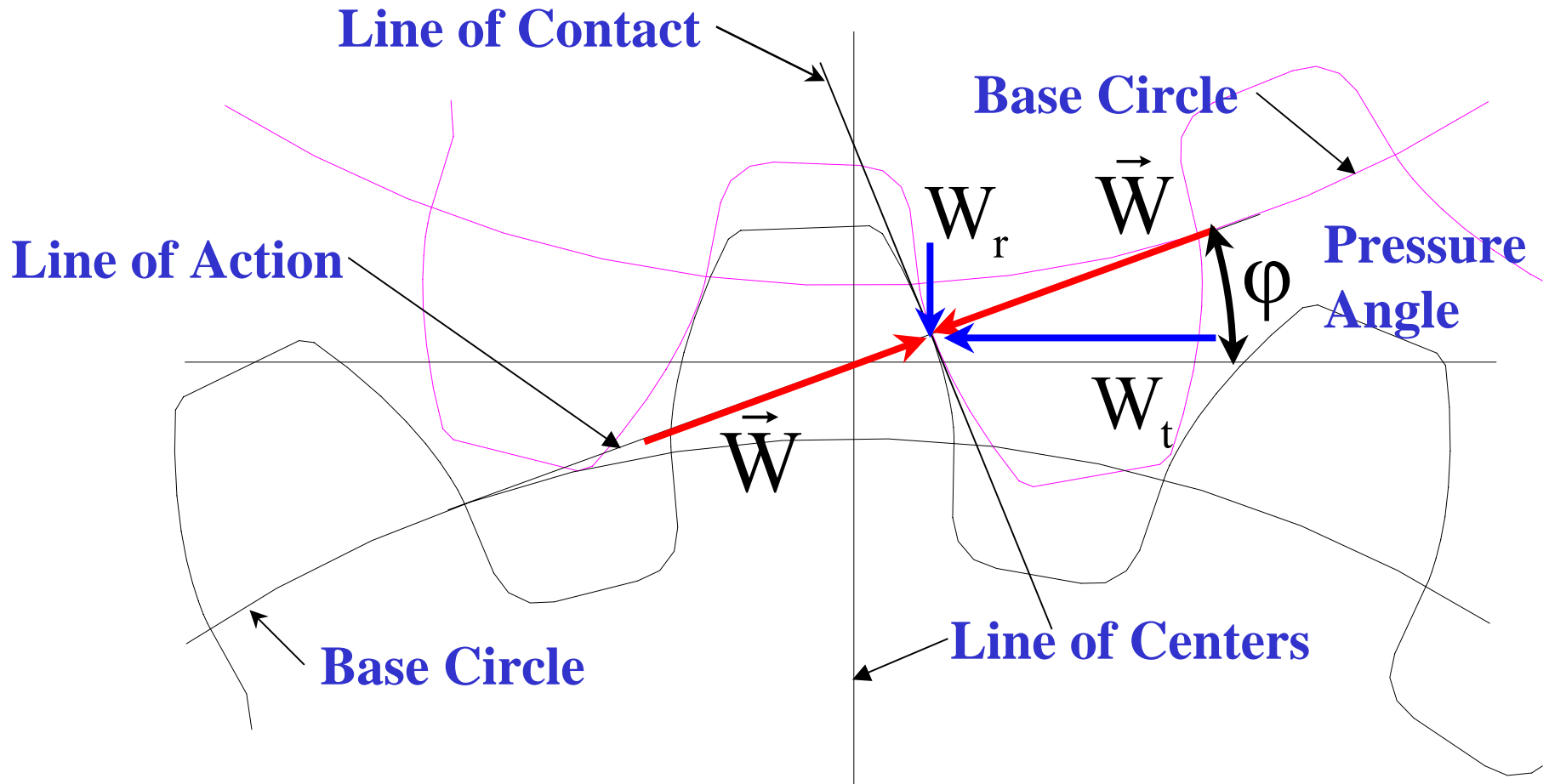

# **Gear Tooth Failure Mechanisms**

The primary failure mechanisms for involute gear teeth are: 1) excessive bending stresses at the base of the tooth and, 2) excessive bearing or contact stress at the point of contact.

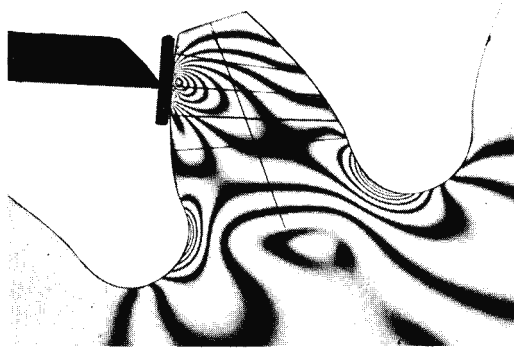

**Deutschman, Fig. 10-20**

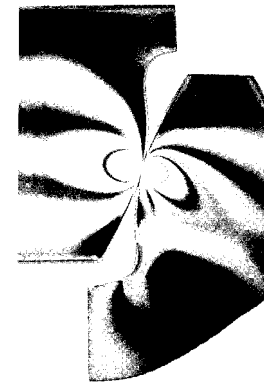

**Mott, Fig. 9-14**

The American Gear Manufacturers Association (AGMA) has developed standard methods for addressing both failure mechanisms.

# **AGMA Publications**

**Standard 1010-95, Nomenclature of Gear Tooth Failure Modes**, AGMA, Alexandria, VA, 1995.

**Standard 6010-E88, Standard for Spur, Helical, Herringbone, and Bevel Enclosed Drives**, AGMA, Alexandria, VA, 1989.

**Standard 2001-C95, Fundamental Rating Factors and Calculation Methods for Involute Spur and Helical Gear Teeth**, AGMA, Alexandria, VA, 1994.

**Standard 908-B89, Geometry Factors for Determining the Pitting Resistance and Bending Strength of Spur, Helical and Herringbone Gear Teeth**, AGMA, Alexandria, VA 1989.

# Lewis Equation

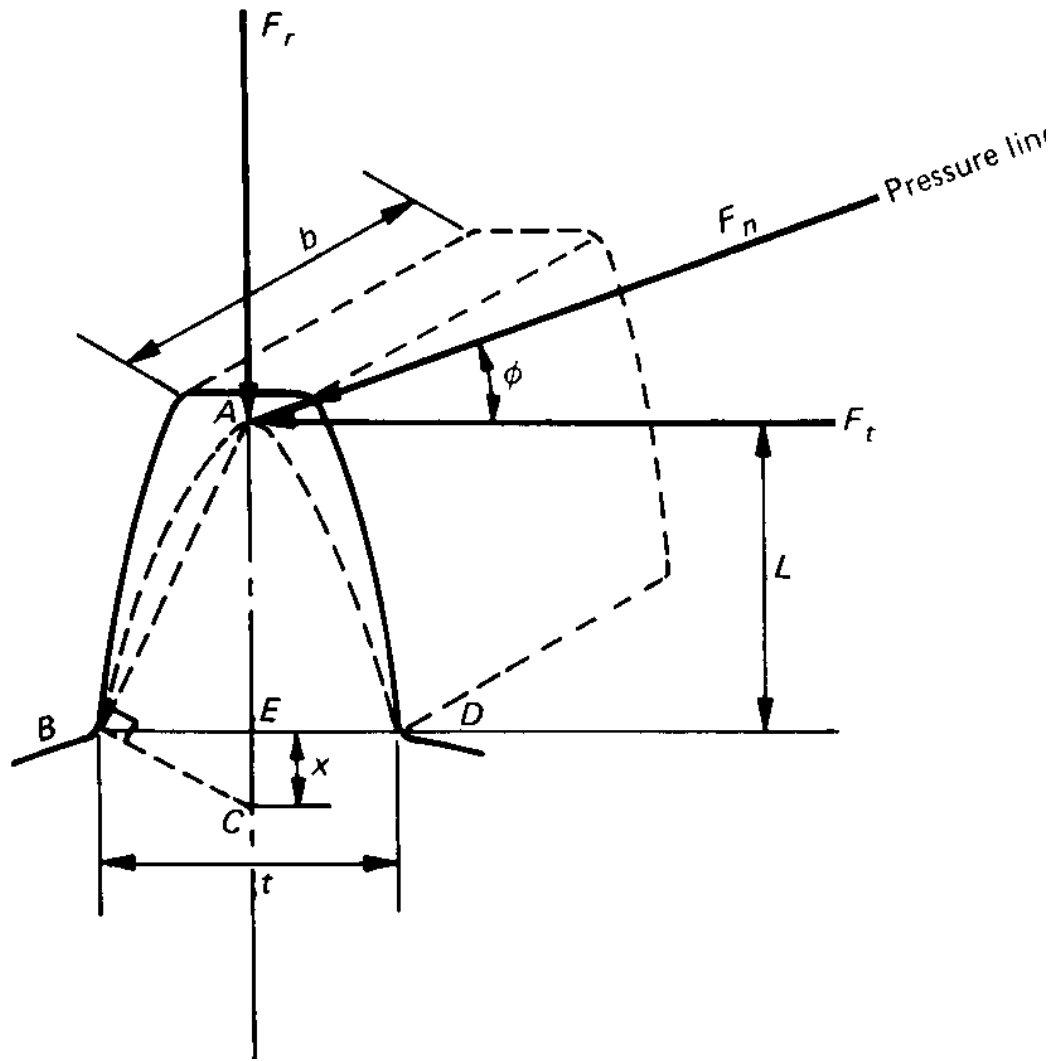

$$\sigma = \frac{M}{I/c}$$

$$M = W_t \cdot L$$

$$I/c = \frac{1}{12} bt^3 / \frac{t}{2} = \frac{bt^2}{6}$$

$$\sigma = \frac{6W_t L}{bt^2}$$

Deutschman, Fig. 10-18

# Lewis Equation (Continued)

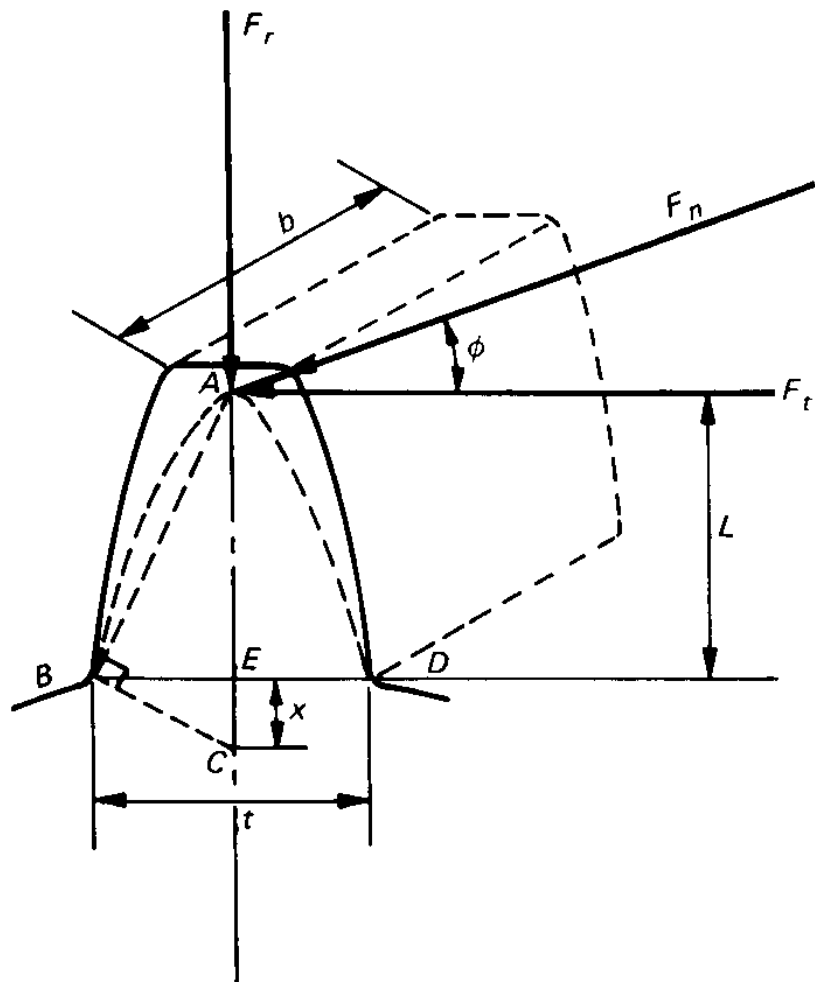

$$\sigma = \frac{6W_t L}{bt^2}$$

$$\sigma = \frac{W_t}{b} \frac{1}{t^2/6L} = \left( \frac{W_t}{b} \right) \left( \frac{1}{t^2/4L} \right) \left( \frac{1}{4/6} \right)$$

$$\frac{t/2}{x} = \frac{L}{t/2}$$

$$x = \frac{t^2}{4L}$$

# Lewis Equation

(Continued)

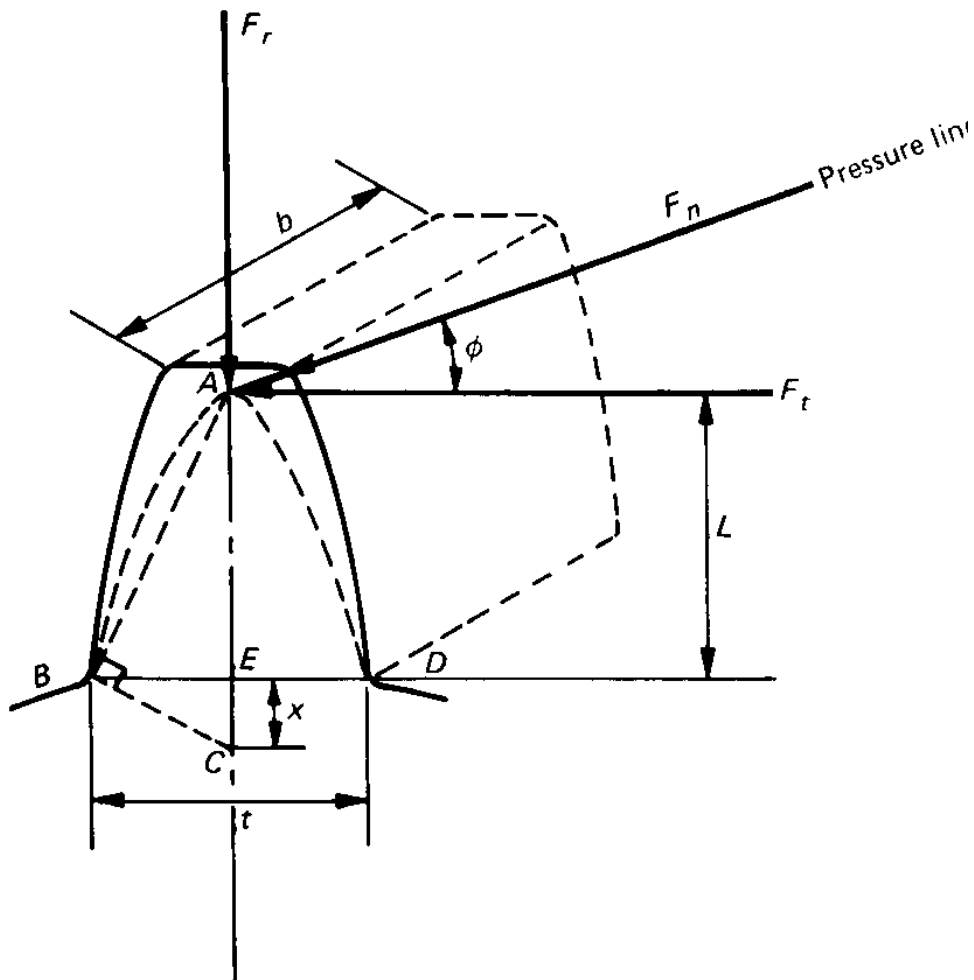

$$\sigma = \left( \frac{W_t}{b} \right) \left( \frac{1}{t^2/4L} \right) \left( \frac{1}{4/6} \right)$$

$$x = \frac{t^2}{4L} \quad p \equiv \text{circular pitch}$$

$$\sigma = \left( \frac{W_t}{b} \right) \left( \frac{1}{x} \right) \left( \frac{1}{2/3} \right) \left( \frac{p}{p} \right)$$

$$y = \frac{2x}{3p} \quad \text{Lewis Form Factor}$$

$$\sigma = \frac{W_t}{bpy}$$

# Lewis Equation (Continued)

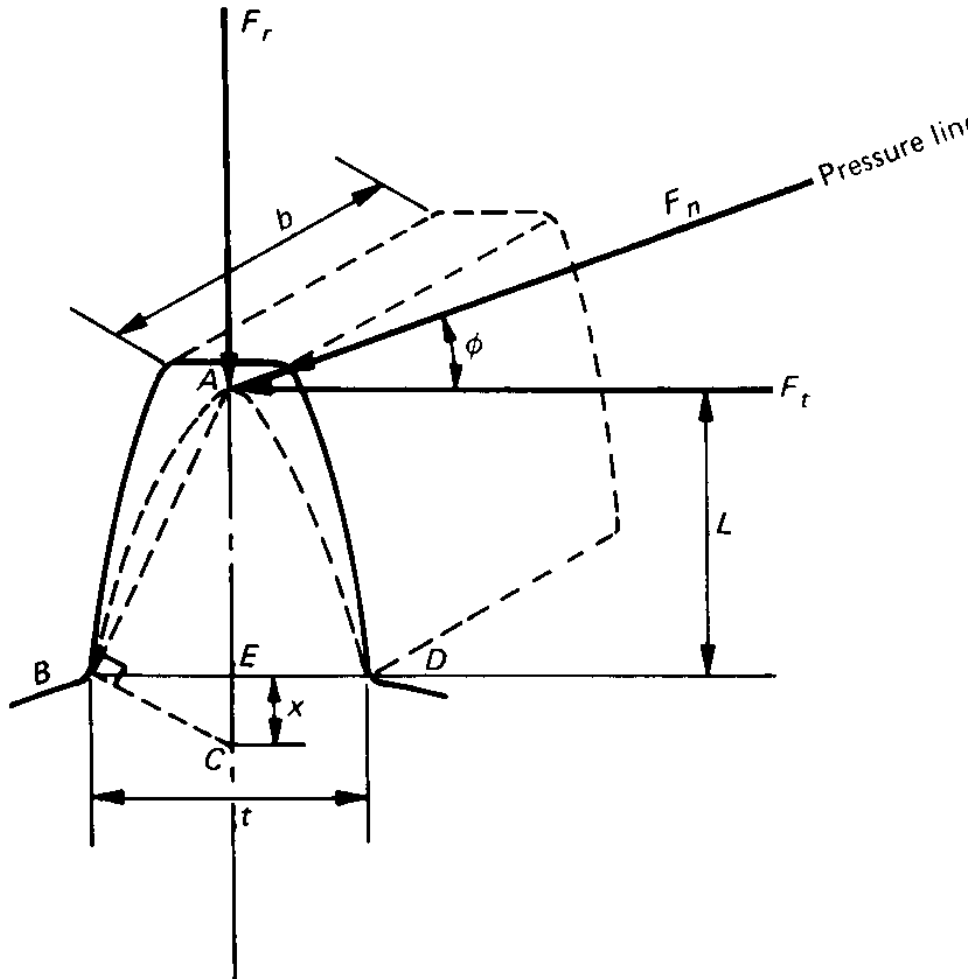

$$y = \frac{2x}{3p}$$

$$\sigma = \frac{W_t}{bpy}$$

$$P \equiv \text{Diametral Pitch} = \pi/p$$

$$Y \equiv \pi y$$

$$\sigma = \frac{W_t P}{bY}$$

Most commonly used form of Lewis Equation

Y can be determined graphically or by a computer.

# Lewis Form Factor

## (Example Values)

NUMBER OF TEETH	Y	NUMBER OF TEETH	Y
12	0.245	28	0.353
13	0.261	30	0.359
14	0.277	34	0.371
15	0.290	38	0.384
16	0.296	43	0.397
17	0.303	50	0.409
18	0.309	60	0.422
19	0.314	75	0.435
20	0.322	100	0.447
21	0.328	150	0.460
22	0.331	300	0.472
24	0.337	400	0.480
26	0.346	Rack	0.485

Values are for a normal pressure angle of 20 degrees, full-depth teeth, and a diametral pitch of one.

$$\sigma = \frac{W_t P}{b Y}$$

# Limitations of the Lewis Equation

1. Assumes that maximum bending load occurs at the tip. Maximum load occurs near the pitch circle when one tooth carries all of the torque induced load.
2. Considers only bending component of the force acting on the tooth. The radial force will cause a compressive stress over the base cross section.
3. Doesn't consider contact stresses.
4. Assumes that the loads are static.

The AGMA has developed a number of factors to be used with the Lewis Equation that will lead to an acceptable design.

# The AGMA Equations

$$\sigma = \frac{W_t P_d}{FJ} \cdot K_a \cdot K_s \cdot K_m \cdot K_v$$

$F \equiv$  face width (b)

$K_a \equiv$  Application factor

$K_s \equiv$  Size factor

$K_m \equiv$  Load distribution factor

$K_v \equiv$  Dynamic factor

$J \equiv$  Geometry factor

$P_d \equiv$  Diametral Pitch =  $N/d$

$d \equiv$  Pitch Diameter

$N \equiv$  Number of Teeth

$W_t \equiv$  Tangential Load

$$\sigma_{\text{all}} = \frac{S_{\text{at}} K_L}{K_T K_R}$$

$S_{\text{at}} \equiv$  AGMA Allowable  
Stress Number

$K_L \equiv$  Life factor

$K_T \equiv$  Temperature Factor

$K_R \equiv$  Reliability Factor

**Factors are used to adjust the stress computed by the Lewis equation. Factors are also used to adjust the strength due to various environmental conditions.**

**Shigley contains tables and charts for many of these factors.**

# AGMA Form Factor

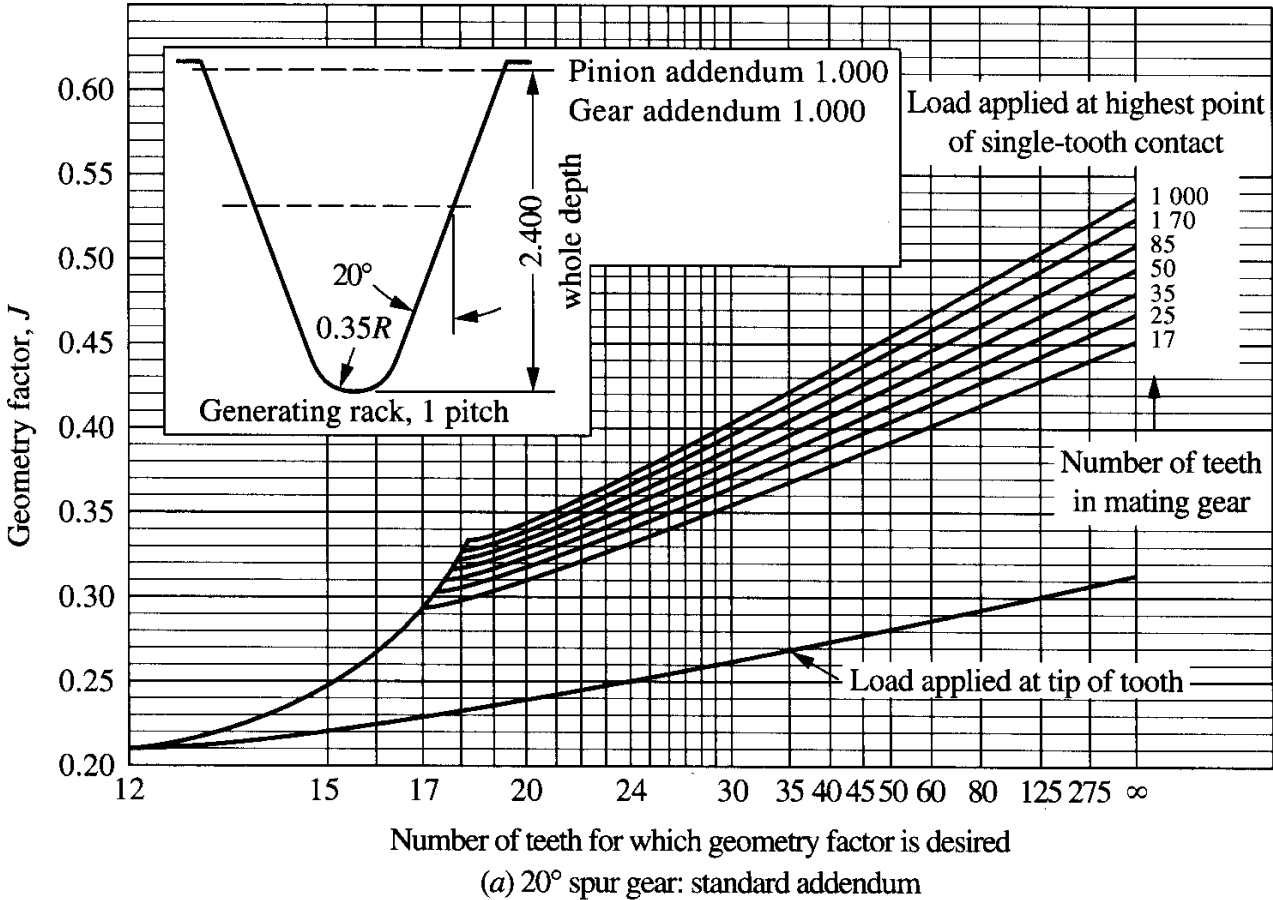

Note that the AGMA Form Factor will result in a lower stress than the Lewis Equation.

# AGMA Allowable Bending Stress Numbers

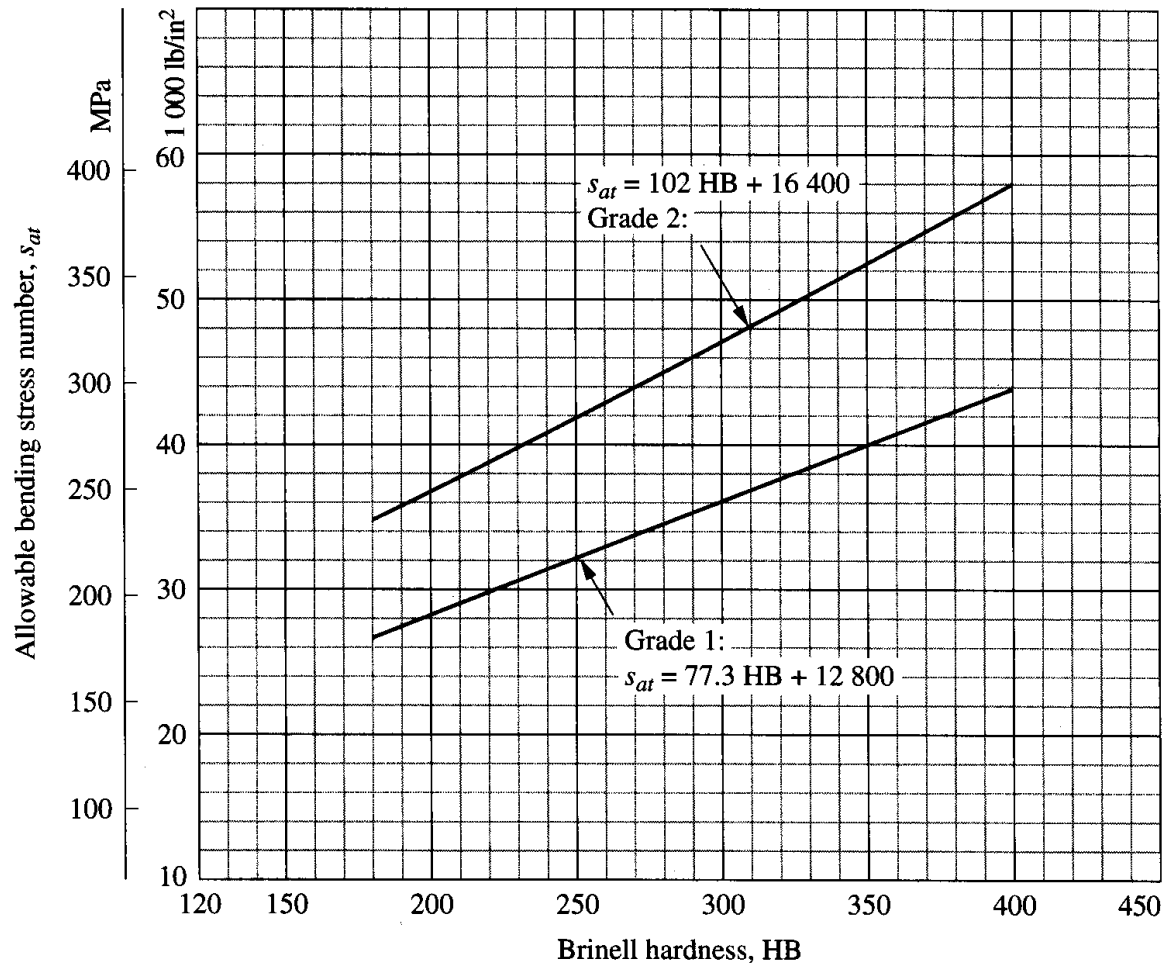

**Grade 1** is the basic or standard material classification.

**Grade 2** requires better than normal microstructure control.

# AGMA Dynamic Factor

The AGMA Dynamic Factor is used to correct the bending stress number for dynamic effects associated with:

1. Inaccuracies in tooth profile, tooth spacing, profile lead, and run-out,
2. Vibration of the tooth during meshing due to tooth stiffness;
3. Magnitude of the pitch-line velocity,
4. Dynamic unbalance of the rotating members,
5. Wear and permanent deformation of contacting surfaces,
6. Shaft misalignment and deflection, and
7. Tooth friction.

# Dynamic Factor Chart

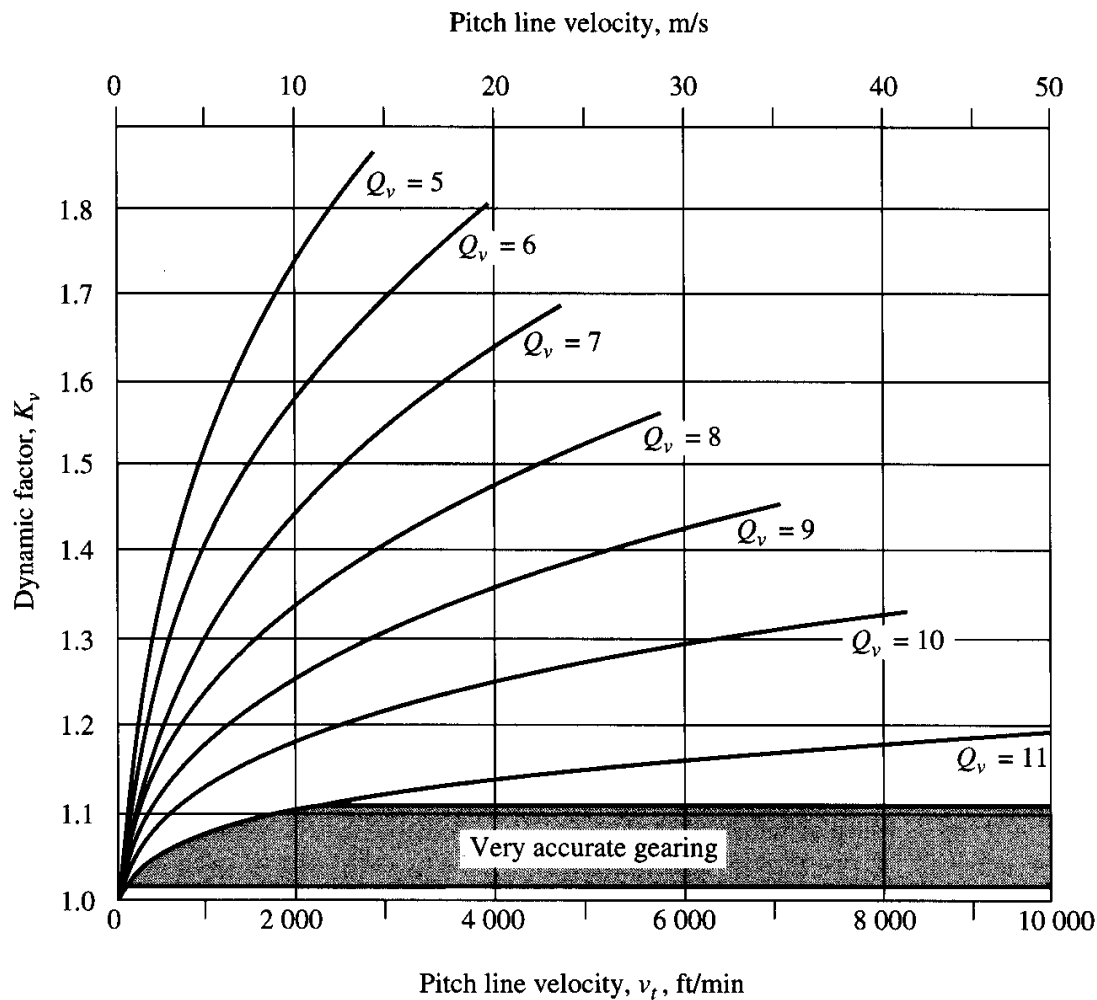

$Q_v \equiv$  AGMA Quality Number

The AGMA standards contain tolerances for each quality number.

Pitch Line Velocity =  $r\omega$

The dynamic factor in Shigley is equal to the reciprocal of the dynamic factor given in this chart.

# Assignment

1. A spur pinion has a pitch of 6 teeth/in, 22 full-depth teeth, and a 20 degree pressure angle. This pinion runs at a speed of 1200 rev/min and transmits 15 hp to a 60-tooth gear. If the face width is 2 in, estimate the bending stress.
2. A steel spur pinion has a module of 1.25 mm, 18 full depth teeth, a pressure angle of 20 degrees, and a face width of 12 mm. At a speed of 1800 rev/min, this pinion is expected to carry a steady load of 0.5 kW. Determine the resulting bending stress.