

## Shaft Analysis

### Lecture 18

Engineering 473  
 Machine Design



## Bending Stresses Due to Stationary Loads

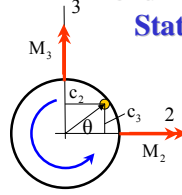

$$\sigma_b = \frac{M_2 r \sin \theta}{I} - \frac{M_3 r \cos \theta}{I} \quad \text{Eq. 1}$$

$$M = \sqrt{M_2^2 + M_3^2} \quad \text{Eq. 3}$$

$$\sin \theta = \frac{M_2}{M} \quad \text{Eq's 4}$$

$$\cos \theta = \frac{M_3}{M} \quad \text{Eq's 4}$$

Combining Eq's 1, 3, and 4

$$\sigma_b = \frac{M_2 r \sin \theta}{I} - \frac{M_3 r \cos \theta}{I}$$

$$\sigma_b = -\frac{M_2^2 r}{I} - \frac{M_3^2 r}{I}$$

$$\sigma_b = -\frac{\sqrt{M_2^2 + M_3^2} \cdot r}{I}$$

## Shaft Stress Equations (Bending and Torsion Only)

Reference	Bending Stress	Torsional Stress
$M = \sqrt{M_y^2 + M_z^2}$	$\sigma_x = \frac{Mc}{I}$	$\tau_{xy} = \frac{Tc}{J}$
$c = d/2$	$\sigma_x = \frac{64Md}{2\pi \cdot d^4} = \frac{32M}{\pi d^3}$	$\tau_{xy} = \frac{T \cdot d/2}{\pi d^4/32} = \frac{16T}{\pi d^3}$
$I = \frac{\pi d^4}{64}$	<b>Principal Stresses</b>	
$J = 2I = \frac{\pi d^4}{32}$	$\sigma_1, \sigma_2 = \frac{\sigma_x}{2} \pm \sqrt{\left(\frac{\sigma_x}{2}\right)^2 + \tau_{xy}^2}$ $\sigma_1, \sigma_2 = \frac{16M}{\pi d^3} \pm \sqrt{\left(\frac{16M}{\pi d^3}\right)^2 + \left(\frac{16T}{\pi d^3}\right)^2}$ $\sigma_1, \sigma_2 = \frac{16}{\pi d^3} \left[ M \pm \sqrt{M^2 + T^2} \right]$	

## Yielding in Ductile Material (No Stress Concentration)

### Distortion Energy Theory

$$(\sigma_1^2 + \sigma_2^2 - \sigma_1 \sigma_2)^{1/2} \leq \frac{S_{yt}}{n_s} \quad \sigma_3 = 0$$

### Circular Shaft

$$\sigma_1, \sigma_2 = \frac{16}{\pi d^3} \left[ M \pm \sqrt{M^2 + T^2} \right]$$

### Distortion Energy Theory for Shaft

$$\frac{16}{\pi d^3} (4M^2 + 3T^2)^{1/2} \leq \frac{S_{yt}}{n_s}$$

## Static Loading Minimum Diameter

$$\frac{16}{\pi d^3} (4M^2 + 3T^2)^{1/2} \leq \frac{S_{yt}}{n_s}$$

$$d = \left( \frac{32n_s}{\pi S_{yt}} \sqrt{M^2 + \frac{3}{4}T^2} \right)^{1/3}$$

This equation is useful in coming up with an initial shaft size early in the design process.

## Shaft Stress Equations (Bending, Axial, and Torsional Loading)

### Axial Stress

$$\sigma_x = \frac{32M}{\pi d^3} + \frac{4P}{\pi d^2}$$

### Principal Stresses

$$\sigma_1, \sigma_2 = \frac{2}{\pi d^3} \left[ 8M + Pd \pm \sqrt{(8M + Pd)^2 + (8T)^2} \right]$$

### Distortion Energy Theory

$$\frac{4}{\pi d^3} \sqrt{(8M + Pd)^2 + 48T^2} \leq \frac{S_{yt}}{n_s}$$

## Fatigue Analysis of Shafts

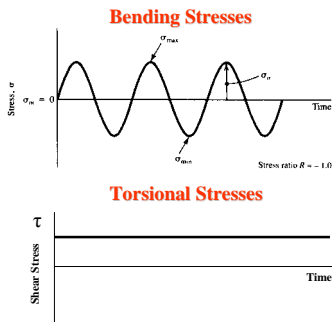

## Shaft von Mises Stress Equation

### Von Mises Equation

$$(\sigma_1^2 + \sigma_2^2 - \sigma_1\sigma_2)^{1/2} \leq \frac{S_{yt}}{n_s}$$

### Principal Stress Equation

$$\sigma_{1,2} = \frac{\sigma_x}{2} \pm \sqrt{\left(\frac{\sigma_x}{2}\right)^2 + \tau_{xy}^2}$$

$$\sigma_1^2 = \left(\frac{\sigma_x}{2}\right)^2 + 2\left(\frac{\sigma_x}{2}\right)\sqrt{\left(\frac{\sigma_x}{2}\right)^2 + \tau_{xy}^2} + \left(\frac{\sigma_x}{2}\right)^2 + \tau_{xy}^2$$

$$\sigma_2^2 = \left(\frac{\sigma_x}{2}\right)^2 - 2\left(\frac{\sigma_x}{2}\right)\sqrt{\left(\frac{\sigma_x}{2}\right)^2 + \tau_{xy}^2} + \left(\frac{\sigma_x}{2}\right)^2 + \tau_{xy}^2$$

$$\sigma_1\sigma_2 = \left(\frac{\sigma_x}{2}\right)^2 - \left[\left(\frac{\sigma_x}{2}\right)^2 + \tau_{xy}^2\right] = -\tau_{xy}^2$$

### Shaft Equivalent Stress

$$\sigma_{\text{eff}} = \sqrt{\sigma_x^2 + 3\tau_{xy}^2} \leq \frac{S_{yt}}{n_s}$$

## Effective Alternating and Mean Stresses

$$\sigma_{\text{eff}} = \sqrt{\sigma_x^2 + 3\tau_{xy}^2}$$

$$\sigma_{\text{eff},a} = \sigma_x$$

$$\sigma_{\text{eff},m} = \sqrt{3}\tau_{xy}$$

Since the bending stress is completely reversed, the only mean stress component is due to the shear stress. Since the shear stress is constant, the only alternating is equal to the maximum bending stress.

## ANSI Standard Fatigue Curve

THEORY	BASIC FORMULA
A Soderberg	$\frac{n\sigma_a}{S_e} + \frac{n\sigma_m}{S_y} = 1$
B Goodman	$\frac{n\sigma_a}{S_e} + \frac{n\sigma_m}{S_u} = 1$
C Gerber	$\frac{n\sigma_a}{S_e} + \left(\frac{n\sigma_m}{S_u}\right)^2 = 1$
D ASME elliptic	$\left(\frac{n\sigma_a}{S_e}\right)^2 + \left(\frac{n\sigma_m}{S_y}\right)^2 = 1$
E Bagci	$\frac{n\sigma_a}{S_e} + \left(\frac{n\sigma_m}{S_y}\right)^4 = 1$
F Yielding (Langer)	$\frac{n}{S_y}(\sigma_a + \sigma_m) = 1$

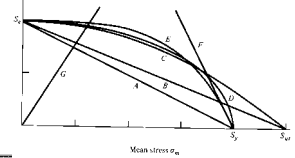

ANSI Standard B106.1M-1985, "Design of Transmission Shafting", American National Standards Institute, 1985, is based on the ASME Elliptic Fatigue Interaction Curve.

## ASME Elliptic Fatigue Equation

$$\left(\frac{n_s k_f \sigma_a}{S_e}\right)^2 + \left(\frac{n_s \sigma_m}{S_{yt}}\right)^2 = 1$$

This equation is used to determine whether the shaft will have infinite life. Note that the fatigue stress concentration factor has only been applied to the alternating stress. Also, the Marin factors need to be used to estimate the endurance limit.

## Minimum Diameter Equation (Bending and Torsion Only)

$$S = \frac{\pi d^3}{32}$$

$$\sigma = M/S$$

$$\tau = T/2S$$

$$\left(\frac{n_s k_f \sigma_a}{S_e}\right)^2 + \left(\frac{n_s \sigma_m}{S_{yt}}\right)^2 = 1$$

$$\left(\frac{n_s k_f M}{S_e}\right)^2 + \left(\frac{n_s T \sqrt{3}}{2S S_{yt}}\right)^2 = 1$$

$$\left(\frac{n_s}{S}\right)^2 \left[ \left(\frac{k_f M}{S_e}\right)^2 + \frac{3}{4} \left(\frac{T}{S_{yt}}\right)^2 \right] = 1$$

$$\frac{32 n_s}{\pi d^3} \sqrt{\left(\frac{k_f M}{S_e}\right)^2 + \frac{3}{4} \left(\frac{T}{S_{yt}}\right)^2} = 1$$

### Minimum Diameter Equation (Bending and Torsion Only)

$$\frac{32n_s}{\pi d^3} \sqrt{\left(\frac{k_f M}{S_e}\right)^2 + \frac{3}{4} \left(\frac{T}{S_{yt}}\right)^2} = 1$$

$$d = \left[ \frac{32n_s}{\pi} \sqrt{\left(\frac{k_f M}{S_e}\right)^2 + \frac{3}{4} \left(\frac{T}{S_{yt}}\right)^2} \right]^{1/3}$$

This equation gives the minimum diameter shaft that will result in infinite fatigue life, and appears in the ANSI Standard.

### Summary of Shaft Stress Analysis Methodology

$$d = \left[ \frac{32n_s}{\pi} \sqrt{\left(\frac{k_f M}{S_e}\right)^2 + \frac{3}{4} \left(\frac{T}{S_{yt}}\right)^2} \right]^{1/3}$$

1. Establish factor of safety that will be used in the design.
2. Draw axial, shear, bending, and torsion diagrams. May require orthogonal shear and bending diagrams.
3. Determine loads acting on the shaft (M, P, and T) at critical locations.
4. Compute stress concentration factors.
5. Estimate endurance limit using test data or  $0.5S_{ut}$  and the Marin factors.
6. Use above equation or equivalent to determine if shaft is acceptable.

### Assignment

The shaft shown in the figure receives 110 hp from a water turbine through a chain sprocket at point C. The gear pair at E delivers 80 hp to an electrical generator. The V-belt sheave at A delivers 30 hp to a bucket elevator that carries grain to an elevated hopper. The shaft rotates at 1,700 rpm. The sprocket, sheave, and gear are located axially by retaining rings. The sheave and gear are keyed with sled runner keyseats, and there is a profile keyseat at the sprocket. The shaft is made from AISI 1040 cold-drawn steel, and has a yield strength of 71 ksi and an ultimate strength of 80 ksi. Using a design factor of safety of 3, determine the minimum diameters at each section on the shaft.

### Assignment (Continued)

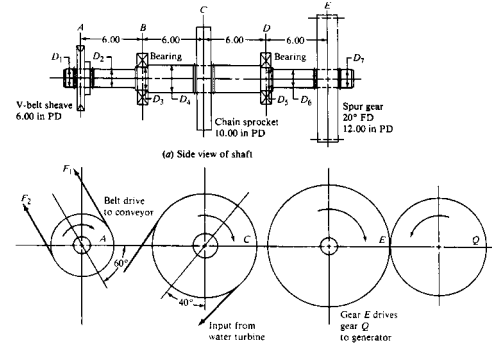

Mott, Figure 12-13